

Product: **Coaxial Isolator**

Part Number: LGL-2/6-SMA

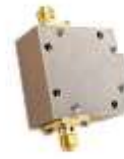

Specification				
No.	Parameter	25℃	-30~+75℃	Units
1	Frequency range	2-6	2-6	GHz
2	Insertion Loss	≤0.6	≤0.7	dB
3	Isolation	≥16	≥15	dB
4	VSWR	≤1.4	≤1.45	dB
5	Impedance	50		Ω
6	Forward Power	20W/cw		
7	Operating Temperature Range	-30~+75℃		
8	Connector	SMA		
9	Direction	1→2→ clockwise		
10	Preferred finish	silver plated		

Mechanical Specifications	
Housing	Aluminum oxidation
Connector	Gold plated brass
Contact:	copper
Rohs	compliant
Weight	0.1kg

Outline Drawing:

All Dimensions in mm

Tolerances : Unnoted tolerances are in class m of GB-T1804-2000

All Connectors: SMA

成都利德尔科技有限公司 ChengDu Leader Microwave Technology Co.,Ltd

电话: 028-65199117 传真: 028-65199116

<http://www.leadermicrowave.com> sales@leader-mw.com

TEL: +86-28-65199117 FAX: +86-28-65199116

Add: 中国 成都市成华区华翰路 89 号 610000

No.89,Huahan Road, chenghua Zone Chengdu, Sichuan China Zip Code:610000

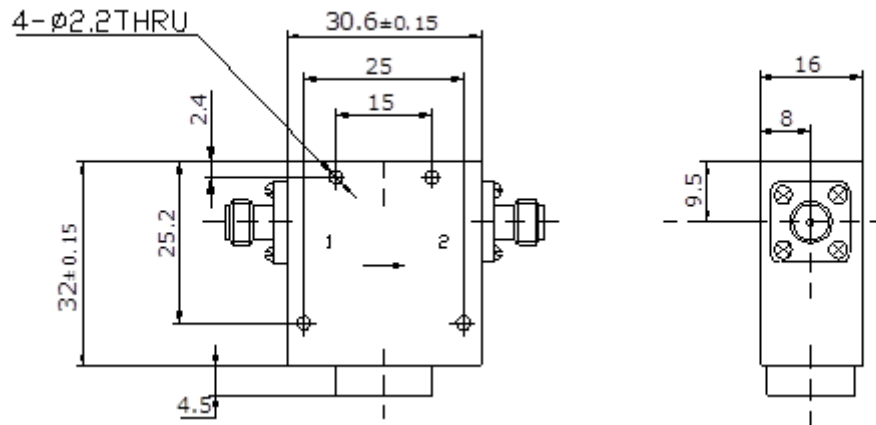

Test data

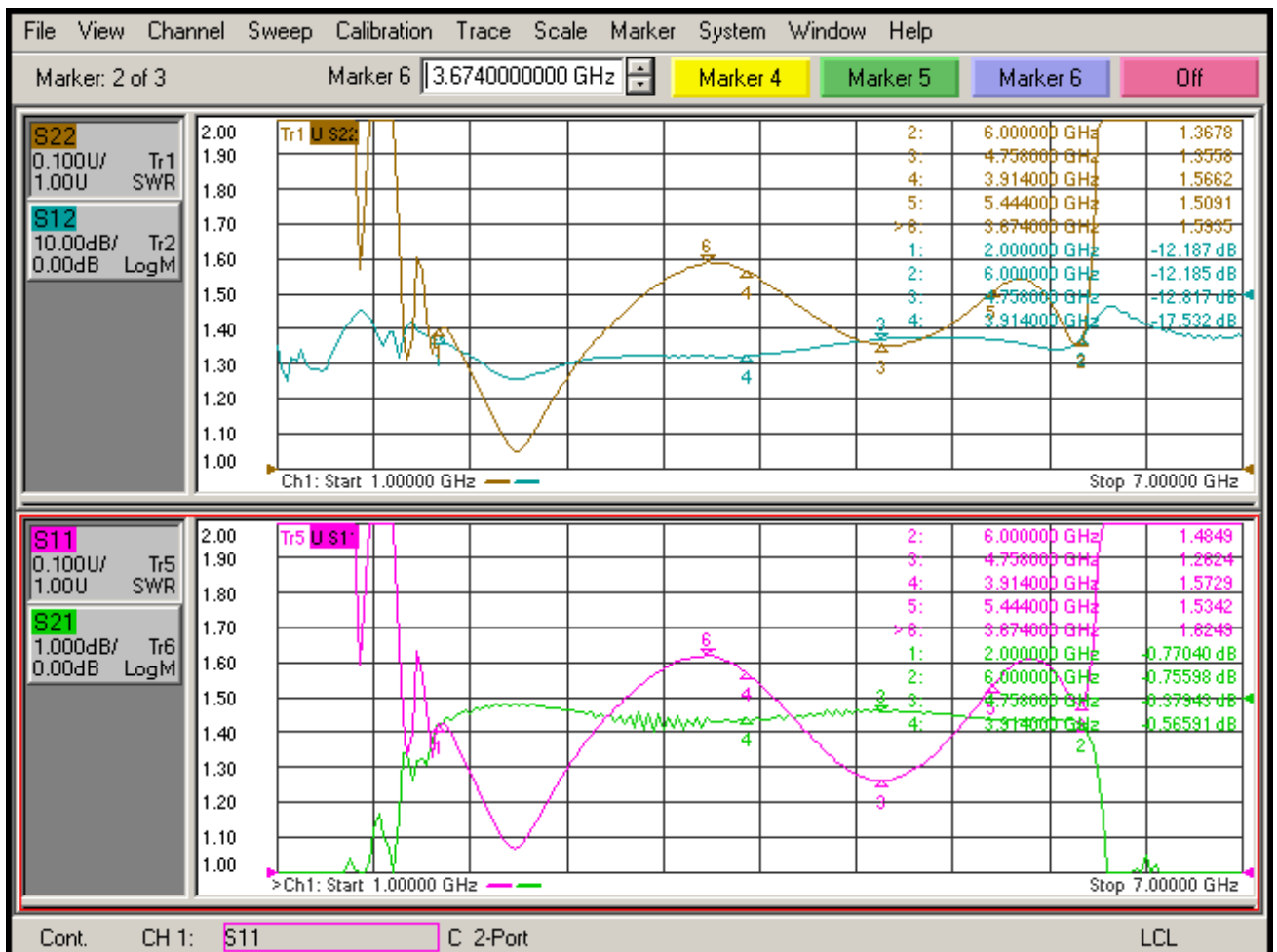

成都利德尔科技有限公司 ChengDu Leader Microwave Technology Co.,Ltd

电话: 028-65199117 传真: 028-65199116

<http://www.leadermicrowave.com> sales@leader-mw.com

TEL: +86-28-65199117 FAX: +86-28-65199116

Add: 中国 成都市成华区华翰路 89 号 610000

No.89,Huahan Road, chenghua Zone Chengdu, Sichuan China Zip Code:610000